

# Continental High-Performance Washer-Extractor, 25 lbs. Capacity, Hard Mount

## REMO25

VENDED HARD-MOUNT WASHER-EXTRACTOR

ARCHITECTURAL/MECHANICAL  
PRODUCT SPECIFICATIONS

PRODUCT SPECS	
Capacity <i>lbs</i>	25
Cylinder Diameter <i>inch</i>	21.1
Cylinder Depth <i>inch</i>	17.3
Cylinder Volume <i>cu ft</i>	3.5
Net Weight <i>lbs</i>	317
Crated Weight <i>lbs</i>	342
Machine Dimensions <i>inch</i> WxDxH	27 x 31.4 x 42.5
Door Opening <i>inch</i>	12.7
Floor to Door <i>inch</i>	15.4
Shipping Dimensions <i>inch</i> WxDxH	27.8 x 32.7 x 49.2
Washing Speed <i>rpm</i>	54
Spin Speed <i>rpm</i>	54/100/410/500/580/600
G-force	48/75/100/108
Static Force Transmitted <i>lbs</i>	428
Dynamic Force Transmitted <i>lbs</i>	589
Frequency of Dynamic Force <i>Hz</i>	10
Available Voltages/Wire Conductor/Amp	120/60/1, 3W, 15 208-240/60/1, 2W+G, 5
Drain Diameter <i>inch</i>	2
Water Inlets <i>inch</i>	2 @ 3/4
Recommended Water Pressure <i>PSI</i>	30-60
Water Flow <i>gal/min</i>	8
Total Power <i>kW</i>	0.35

\* Specifications subject to change without notice or obligation. Contact Continental Girbau at (800) 256-1073 for dimensions not shown or for clarification.

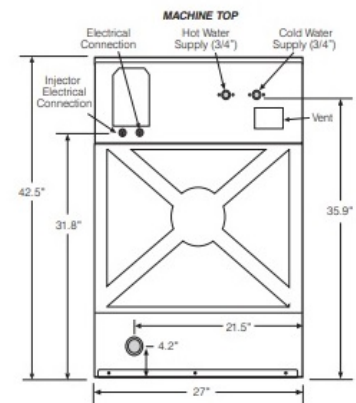
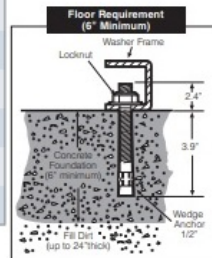
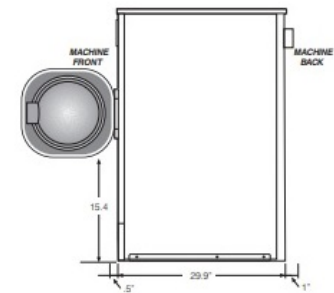
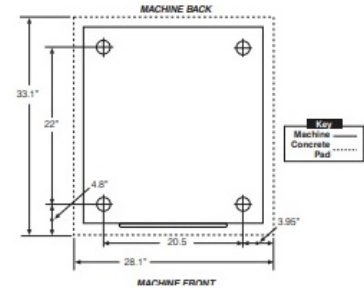

\*We will be using the 120V/60/1.3W,15 Model